

Multiple V-V mono-eventive syntactic complex in Mayangna

Elena Benedicto and Elizabeth Salomón
Purdue University and URACCAN

In this paper we propose a structural analysis for an, as of yet unidentified, mono-eventive V-V complex in Mayangna. We identify three different subtypes and propose an underlying structure based on different levels of application of the Merge operation; different structural layers are identified: aspectual, transitivity, complex path and result state, as in (44).

The language shows that different structural mechanisms are used in Complex Movement predicates to encode Manner (of Movement) and to encode Complex Path.

1 Mayangna Verb Combining Devices and Serial Verb Constructions.

Mayangna presents a relatively well-studied system of SVC which incorporates a morphological Switch Reference System with a Same-Subject (Proximate) paradigm and a Different-Subject (Obviative) paradigm (Norwood, 1997; Hale 1989, 1991, 1992, 1997). This system is used for a variety of configurations (Sequential, Causative, Perception structures, etc...), some of which are mono-eventive while some are not. Here are some examples:

- (1) Nawah as **talik** îranayang
Tiger D_{-def} see.SS1s run.PST1s
'I saw a tiger and I ran'
- (2) Nawah as **taling** kîrana
Tiger D_{-def} see.DS1s run.PST3s
'I saw a tiger and it ran'

Examples (1) and (2) are cases of sequential SVCs and the crucial element in them is the agreement morpheme (1st person singular in both) appearing on the first verb, the first one (*-ik*) indicating identity of reference with the following verb and the second one (*-ing*) indicating disjoint reference with the subject of the following verb.

In the structures that we deal with in this paper, as of yet unidentified, the initial verbal forms are bare, that is, they contain no verbal morphology of any kind, agreement or otherwise. The following is an example:

- (3) dî as ûnitak kidi tak pamnin
thing D_{-def} skin-POS3s D peel.∅ PAMNIN.INF
'to peel something'

In (3) we can observe that the first verb (*tak*) appears in its bare root form, contrary to what we could observe in (1)-(2) (*talik* and *taling*, respectively).

Here we concentrate on the structure in (3) and we determine its types, properties and corresponding underlying structural configurations.

2 The Mayangna V-V complex.

The structures of the type in (3) show the following properties:

- (4) a. they contain multi-verbal sequences (V-V, V-V-V, ...);
- b. they are all mono-eventive;
- b. they contain verbal units with no inflexion except for the last one.

Three different sub-types have been identified:

- (5) a. Aspectual;
- b. Intransitive Complex Path;
- c. Transitive Complex Path.

In the Aspectual sub-type, the last verb, which contains the sentential inflection, has been grammaticalized for aspectual properties. The example in (3) before, repeated here for convenience is a case of this sub-type:

- (6) dî as ûnitak kidi tak-∅ pamnin
 thing D_{def} skin-POS3s D peel.∅ PAMNIN.INF
 ‘to peel something’ (and be done with it at once)

Sub-types (5)b-c encode the complex path of a movement predicate, the first one in an unaccusative intransitive formation, the second one adding an agent and thus forming a transitive predicate. Examples (7) and (8), respectively, are a case in point:

- (7) was yak kâ-∅ kiuna
 river P enter.∅ go.PST3S
 ‘s/he got into the river’
- (8) mutsila dû-∅ lau-tah (yaklaunin, ‘stand up’)
 backpack have.∅ stand_up.IMP2s
 ‘put the backpack up!’

2 The Hypothesis.

In this paper we propose that the bare V-V complex is the result of merging at different levels, below or at little *v*, contrary to what happens with cases like those in (1)-(2), which would correspond to merging above little *v*. Our Hypothesis, thus, can be stated as in (9) below:

- (9) The *V-V Complex Hypothesis*
 - i. bare V-V complex is the result of Merge below *v*
 - ii. different structural levels of Merge underlie the sub-types in (5), as specified in (10) below.

(10)

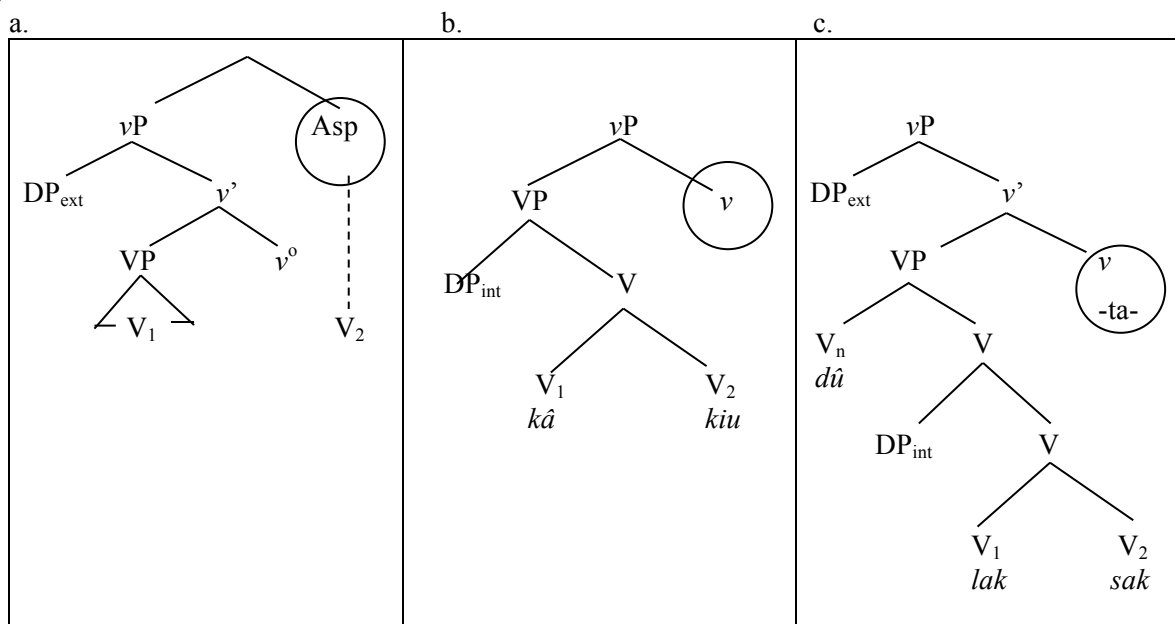

The structure in (10)a. corresponds to the Aspectual type in (5)a., where the aspectually grammaticalized final verb heads an Asp head; this verb will then be subject to other syntactic operations by which it will end up carrying the corresponding sentential inflection (Tense and Agreement).

The structure in (10)b. corresponds to a movement predicate, with a complex path specification (V_1, V_2) under an unaccusative v , the intransitive type of (5)b. Finally, (10)c. corresponds to the merging of a complex path specification structure (V_1, V_2) with a V_n triggering a transitive v , that is, a v that introduces an external (agentive) argument (DP_{ext}).

4 The Structural Types of Syntactic V_f - V_f .

In this section we will address the properties observed in each of the types identified in (5) above and will evaluate how they behave with respect to the structures proposed in (10).

4.1 $\langle V_f$ - $V_f \rangle$, with V_f =aspectual.

As mentioned before, the last verb in this V-V complex has been grammaticalized to encode aspectual meaning, while coexisting with its original non-grammaticalized lexical counterpart. In (11) below, we list the three items identified thus far with their lexical counterpart:

(11) Values for V_f =aspectual

<i>pamnîn</i>	'to throw'	>>	completed event without specification of process
<i>dânîn</i>	'to leave (sth)'	>>	culminated process
<i>lânîn</i>	'to cross'	>>	change of state

Let us now look at them individually.

pamnîn

This element that originally means 'to throw' and 'to fish' (by throwing the *kuyulh*) encodes the aspectual meaning of completed event without specifying the process involved. Here are some examples:

- (12) rumh pamnayang
 throw_away.∅ PAMNIN.PST1s
 ‘I threw it away’ (and I’m done with it)
- (13) âdika wasni dî.∅ pamtah
 this water drink PAMNIN.IMP2s
 ‘drink up that *fresco!*’ (at once, not little by little)

The requirement for the lack of reference to the process becomes evident when the lexical predicate refers to a long complex process that cannot be obviated, as is the case with *alahus wis* ‘to harvest the rice’ below:

- (14) warmani alahus wis.∅ *pamtah (/√dâtah)
 today rice harvest PAMNIN.IMP2s / DÂNIN.IMP2s
 ‘go harvest the rice today (at once)!’ (/√finish harvesting today!)

In this case, *pamnin* is unacceptable while *dânin*, which indeed targets the process in a predicate as we will see next, is acceptable.

When the process portion of an event can be obviated, then both options are possible (with the corresponding change in meaning). Thus, in (15)a. the meaning of the main verb allows the process portion of its meaning to be obviated and the use of *pamnin* is allowed; in (15)b, on the contrary, the aspectual *dânin* targets precisely the process portion and, under that interpretation, its use is allowed:

- (15) a. bakan pamtah
 buy/sell.∅ PAMNIN.IMP2s
 ‘sell it already (... I’ll come back tomorrow for another one)’
 Context: I’m in the market looking at an object to buy when another lady comes and also shows interest in the object; the speaker utters (15)a. thus allowing the seller to sell it to the other buyer.
- b. bakan dâtah
 buy/sell.∅ DÂNIN.IMP2s
 ‘be done with your buying (... I’m in a hurry and I want to go now...)’
 Context: A husband and wife are in the market looking at an object to buy; the wife is looking at it and considering whether she is sufficiently interested or not, and asking questions about it; the husband becomes impatient and utters (15)b to end the process.

dânin

The original lexical meaning of this element is ‘to leave something somewhere’ and it has been grammaticalized into that of culminating an event’s process, the end of that process. Here are some examples:

- (16) asna yaunik balna bitik suh dânyang
 clothes wash.INF1s PL all wash.∅ DÂNIN.PST1s
 ‘all the clothing that I had to wash, I finished washing’

The question arises as to the scope of this aspectual element, that is, is the object under its scope (thus producing a telic event) or outside. Let us consider the following modified example:

- (17) yang pat asna suh dânayang
 PRN.1s already clothes wash.Ø DÂNIN.PST1s
 ‘I am already done washing the clothes’

In this case, there are two possible readings: one in which there are still clothes to wash but I’m done for the day (non-telic reading: object not affected); and one where there are no more clothes to wash (telic reading: affected object).

The answer to the above question is then that the telic reading is possible but not obligatory. We can suggest a way of dealing with this along the lines of optional movement of the object to the Spec of the Asp head (see (10)a.), in the spirit of proposals like Borer (2005).

lânin

Originally meaning ‘to cross over’, this element has been grammaticalized into an aspectual meaning of change of state. Here are some examples:

- (18) ... dawak yamni buh lâlâna
 and well dry.Ø LÂNIN.PST3p
 ‘... and they dried out well’

(18), as a continuation to (16) or (17), indicates the change of state from wet to dry.

The lexical meaning of the base predicate seems to have an effect on the use of the corresponding aspectual head:

- (19) a. tîbil/ ûpas us lânayang (/ pamnayang / dânayang)
 table/house clean.Ø LÂNIN-PST1s / PAMNIN-PST1s / DÂNIN.PST1s
 b. tîbil/ ûpas suh *lânayang (/ pamnayang / dânayang)
 table/house clean.Ø LÂNIN- PST1s (/ PAMNIN- PST1s / DÂNIN.PST1s)

In (19)a., the predicate *us* ‘to clean’ involves a cleaning with something wet and implies a short process, with a clear change of state; *lânin* is thus compatible (as is *pamnin* obviating the process part of the event, and *dânin* targeting precisely the process part of the event). In (19)b., however, the predicate *suh* also ‘to clean’ involves, on the contrary, a long and complex process which does not accept *lânin*,¹ seemingly indicating the lack of availability of a change of state, whereas the acceptability of *pamnin* and *dânin* indicates the availability of a process that can be obviated.

4.2 <V_i... V_n-V_f>, with V_i... V_n-V_f = complex path (movement).

This V-V complex type is used to encode complex movement predicates. It does not, however, encode the more well-known type of complex movement, that of manner of movement. Manner of movement is encoded using the other V-combining device presented above in (1)-(2), using the Switch Reference paradigm, as shown in the following examples:

- (20) a. *balh kiuna
 fly.Ø go.PST3S
 b. balhwi kiuna
 fly.SS3s go.PST3S
 ‘s/he flew (away)’ (fly-went)

¹ It may be interesting to further investigate whether *usnin* but not *suhnin* encodes a result state or not. A similar contrast exists in Spanish between *lavar* ‘to wash’ (√ *lavado*, result past participle) and *limpiar* ‘to clean’ (* *limpiado*, result past participle).

- (21) a. *kar lakwanayang
roll.∅ go_down.PST3S
- b. kartik lakwanayang
roll.SS3s go_down.PST3S 'I rolled down (the hill)'

The bare V-V complex that occupies us here is used instead to encode a complex path. The following are some examples:

- (22) a. truk lak-∅ kiuna
truck go_down.∅ go.PST3S
'the truck went down (the hill)'
- b. truk kil-∅ kiuna
truck go_up.∅ go.PST3S
'the truck went up (the hill)'

In the previous examples, the last V, *kiuna*, encodes movement towards or away from the speaker (or the reference point); in that sense, we can identify it as 'deictic.' The previous V, *lak* 'to go down' or *kil* 'to go up', indicates movement along the vertical axis.

We can conceptualize this system as a reflection of a Cartesian Coordinate System,² using three axes representing a three-dimensional space representation.

(23)

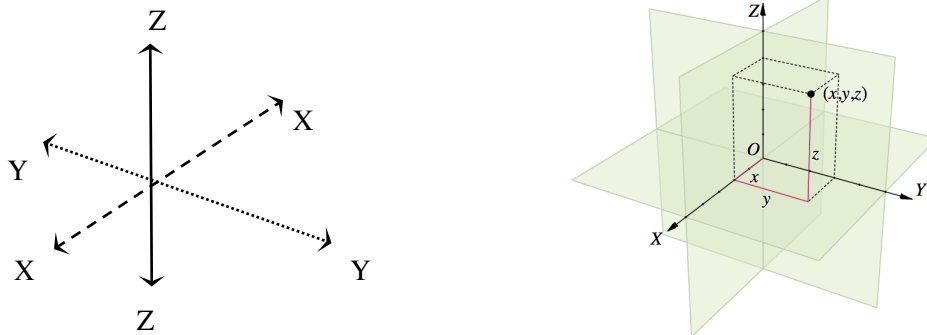

Linguistically, such a system can be used to encode movement along planes defined on the basis of these axes, with respect to a reference point, as follows: Z for the vertical axis (up/down), Y for the horizontal, sideways, axis (across); and X for the deictic (away/towards the reference point):³

(24) a. Z plane (vertical)

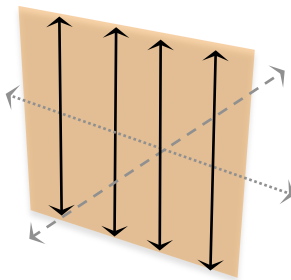

b. Y plane (horizontal)

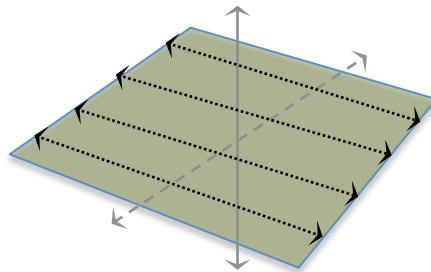

c. X plane (deictic)

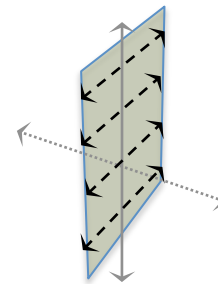

² The figure in (23) is taken from: http://en.wikipedia.org/wiki/Euclidean_space, accessed August 2011.

³ Interestingly enough, from a crosslinguistic point of view, we can see this system reflected in languages geographically and genetically as unrelated as SwaTawWe (Sino-Tibetan; Zheng, 2012) or the organization of space in Sign Languages.

(29) a.

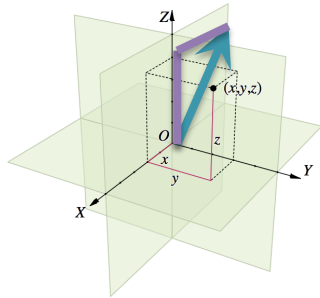

b.

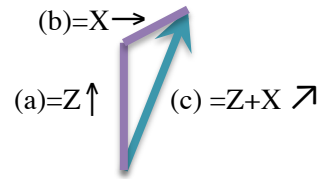

The structure that we are proposing for this type, along the lines of the one stated earlier in (10)b, is the one we find in (30), with direct Merge of the roots in the order established:

(30)

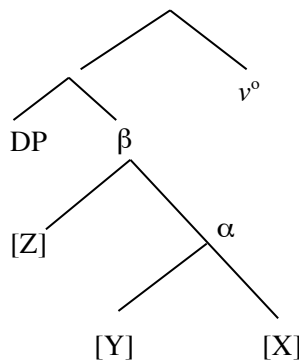

This structure leaves the right-most V root as the one that will stay (linearly) adjacent to the sentential head-final inflection of the language; that's why *kiuna* in the previous examples carries the Past tense inflection of the sentence.⁴ We will come back to this issue in the next sub-section, when we consider whether we only have surface linear adjacency or head movement.

From a compositional semantic point of view, the denotation of the α and β nodes would need to be calculated via some variation of Event Identification (Kratzer, 1996), which would yield the mono-eventivity of the structure and the fact that all the V roots share one single internal argument (DP), as unaccusative roots.

A final point to address in this subsection is the role of elements like *kânin* in (7), repeated here for convenience:

- (31) was yak kâ- \emptyset kiuna
 river P enter. \emptyset go.PST3S
 'S/he/it went into the river' (lit: enter-went)

We contend that the role of *kânin* in these cases introduces the end point argument of the complex predicate, thus playing the role of a telicity marker. Its absence will indicate the general direction of the movement but not 'entering into the river' (by drowning or by sinking):

- (32) was yak kiuna
 river P go.PST3S
 'S/he/it went towards the river'

⁴ The tree in (30) is a partial tree, that will be subject to further Merge of inflectional heads (Asp, T, etc...)

The tree in (30) implies a different directionality for lexical and functional heads, something that is not uncommon crosslinguistically. If this is in the right direction, and if *kânin* in V-V complexes is indeed a telicity marker, then it behaves along lexical roots (left-merged) and not functional heads (right-merged), thus making a difference between ‘inner aspect’ (or Aktionsart) and ‘external’ aspect (as illustrated by the first subtype in 4.1). We leave the implications of this issue for further research.

4.3 <V_i-V_f> + -ta , (complex path) movement + agent.

The specific characteristic of this sub-type is the fact that it adds an agent to the predicate, that is, it transforms an (unaccusative) intransitive predicate into a transitive one. Additionally, it can also present a result sub-structure or a beneficiary sub-structure (in complementary distribution).

Let us begin by considering some examples:

- (33) mutsila dû lau-tah
 backpack have.∅ stand_up.IMP2s
 ‘pick up the backpack!’

In (35) we can observe how, out of the (unaccusative) intransitive *yaklaunin* ‘to stand up’ we obtain a transitive predicate by adding *dû* (from *dûnin* ‘to have’). Evidence for the fact that the resulting complex predicate is transitive comes not only from the interpretation associated with (33) but also from the presence of the morpheme *-ta* in sentence final position.⁵ Movement verbs’ (in)transitive alternations is reflected in their verbal morphology: intransitive inflection is *-wa* while transitive is *-ta*:

- (34) (yang) lau-wa-yang ‘I get up / I stand up’
 (man) lau-wa-man ‘you get up / you stand up’

The presence of the initial verb *dûnin* ‘to have’ is not necessary. The example in (35) does not have it, still showing the transitive *-ta* morpheme, while the case of (36)a., corresponding to the prompt in (36)b., has a different one, *mur* ‘to pull’:

- (35) mutsila il-∅ sak-tah⁶
 backpack go_up be(at).V_EST-trIMP2s
 ‘get the backpack up (and leave it / let it be) !’

- (36) a. mur lâ wit-tah
 pull cross be(-hanging).V_EST-trIMP2s
 ‘pull it over (while hanging)!’

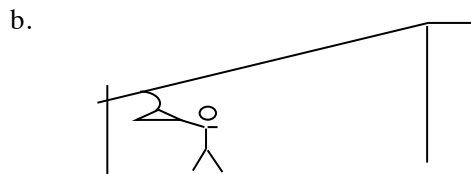

⁵ Intransitive *yaklaunin* also has an additional mark of intransitivity: the prefix *yak-*. However this morpheme is only present in 3rd person singular, and the example in (33) is 2sg.

⁶ (*K*)*ilnin* ‘to go up’ is also a verb whose (in)transitivity shows through verbal morphology as in (34) and a prefix, *k-* in this case, for 3rd person. Like in the case of (33), however, the examples is in 2sg and thus the (3rd person) *k-* does not appear.

What makes (35) and (36) interesting is the fact that they show that the verbal inflectional element *-ta*, indicating transitivity, appears (right) adjacent, not to the initial transitive verb (*dû* in (33), *il* in (35) or *mur* in (36)), but to the totality of the V-V complex, right after the last element.

This is especially interesting because of the nature of that last element in (35) and (36), *sak* and *wit*, respectively. These elements belong to a paradigm of five (positional) stative verbs (Norwood, 1997; Benedicto, 2002) with a particular inflectional paradigm, clearly distinct from regular lexical verbs. These elements take the (Person) Agreement morphology directly and can never take verbal elements like *-ta-* or *-wa-* obligatory in verbal elements:

- (37) a. (yang) sak yang
(man) sak man
(witing) sak ki
- b. * sak-**ta**-yang
- c. * sak-**wa**-yang

The fact that the transitivity morpheme appears adjacent to them together with the impossibility of (37)b. (and c.) shows that such a morpheme is not attached to that element itself but to the totality of the V-V complex. We will address this particular property in the revised structure we propose at the end of this section.

A further property of this subtype is the fact that the transitive V of the V-V complex must appear at the absolute left edge of the V-V compound, after the complex path sub-structure:

- (38) dû lau il sak tayang
have stand_up go_up be(at).V_EST-trPRS1s
'(s/he) raises it up (& lets it be)'

In summary, the transitive V in the V-V complex must appear in absolute initial position, whereas the transitive inflection that it triggers must appear at the V-V complex absolute final position. This is captured by the structure proposed in (10)c., repeated here for convenience, where the transitivity marker instantiating little *v* takes the VP formed by the V-V complex via successive Merge of its individual Vs:

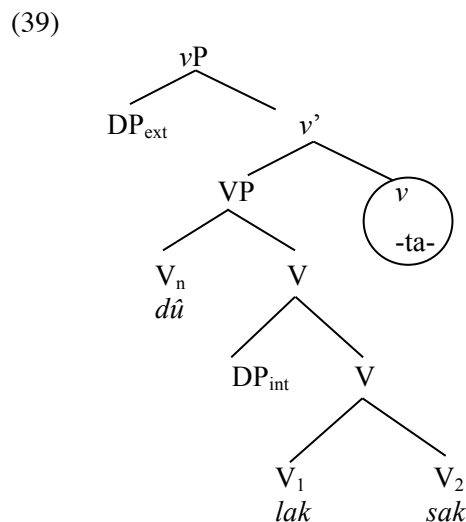

In addition to the transitivity of this subtype, we also identified a result sub-structure, contributed by the stative verbs *sak* and *wit* in the above examples, (35)-(38). Though this sub-structure does not seem to be required (see (33)), it is incompatible with the presence

of another optional sub-structure, that of a beneficiary: compare (40) a. and b. with (41) below.

- (40) a. *dû* *lau* *sakna*
 have stand_up be(at).V_EST-trPST3s
 ‘(s/he) raised it (& let it be)’
- b. *dû* *lau* *yâna*
 have stand_up O1s.give.PST3s
 ‘(s/he) raised it up to me’
- (41) *dû* *lau* **sak* *yâna*
 have stand_up be(at) O1s.give.PST3s

The structure in (39), however, does not account for this incompatibility. In order to address this issue, we will revise this initial structure along the lines of a Larsonian VP-shell analysis proposed for ditransitives. This type of approach proposes two layers for these predicates, where the lower one corresponds to a predication structure; the V in that lower structure then raises to the upper one leaving the DP subject of the lower predication as the ‘object’ of the resulting (di)transitive structure. In a head-initial language like English, the structure for predicates like ‘put something somewhere’ or ‘give something to someone’ would be as in (42), with the final lexical verb (‘give’ or ‘put’) as the output of the complex head V+V:

- (42) VP-shell analysis for ditransitives

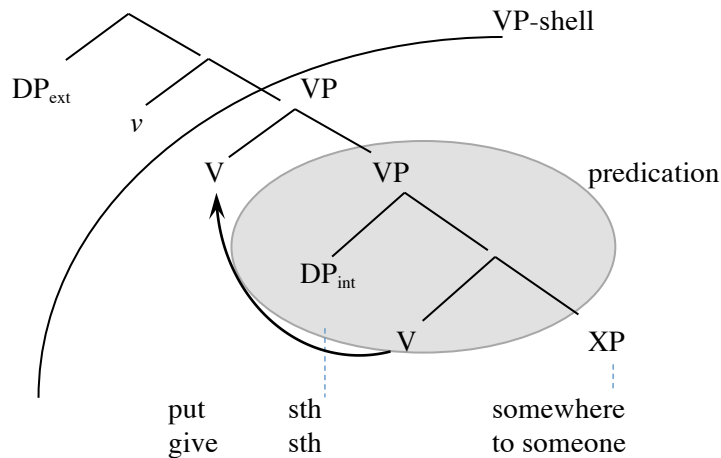

We will propose that, in Mayangna, the upper V is represented by the initial *dû* while the lower V is lexically represented by the stative verb (as in (40)a.) or by the dative marking ‘give’ V in (40)b. The reason why these two elements are incompatible, as we saw in (41) is precisely because they are competing for the same position, the lower V.

The final structure proposed for this subtype, thus, is the one we set in (43), with a lower predication layer (A) and an upper transitivity layer (B), with independent lexicalization of the individual V heads (and further raising of the internal arguments for Case purposes):

(43)

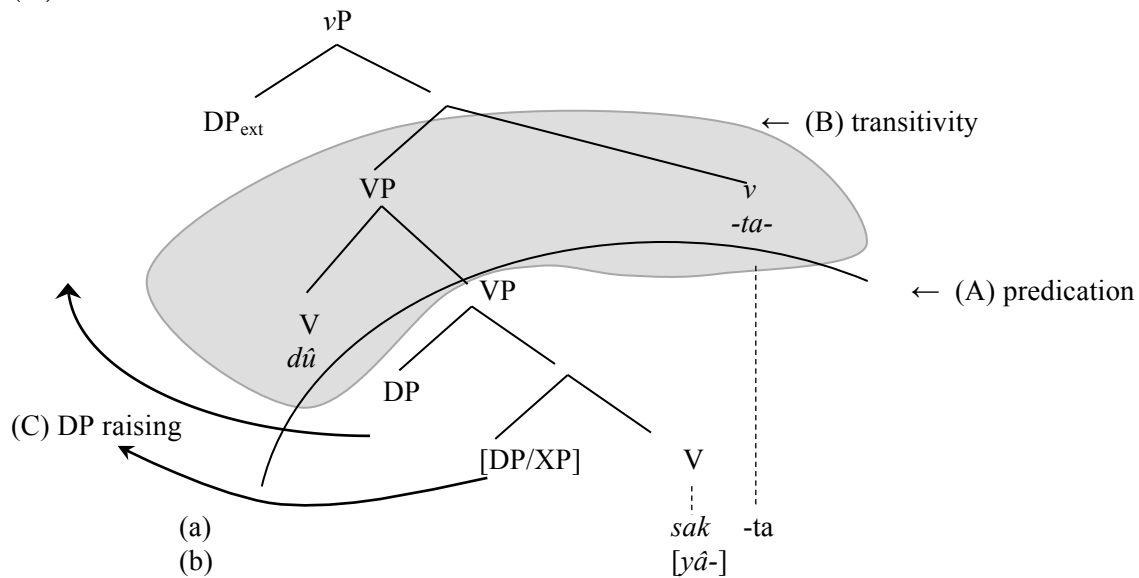

The structure proposed in (43) then accounts for all the properties identified for these structures: (i) the ‘left-edge’ effect for the transitive V in the V-V complex; (ii) the ‘right-edge’ effect of the transitivity marker; (iii) the surprising and unexpected apparent attachment of the transitive marker to the final stative element (as a surface linear adjacency by-product out of the structural adjacency of *v* and *VP*); and (iv) the complementary distribution of the final stative element and the beneficiary element.

5 Conclusions.

In this paper we have identified a new type of syntactic V-V complex, with at least three different subtypes. We have proposed that these three types are the result of merging at different levels with a potential layered structure of the type in (44):

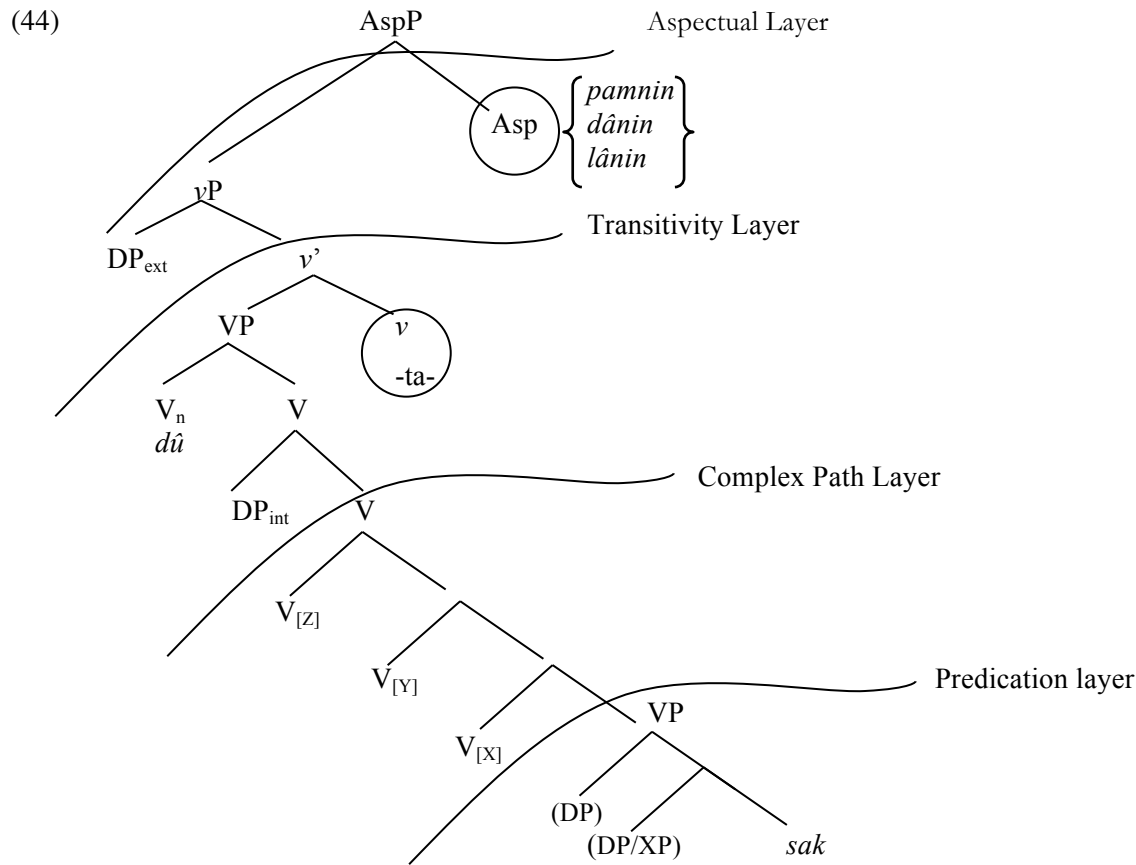

References

- Benedicto, Elena. 2002. Verbal Classifier Systems: the exceptional case of Mayangna auxiliaries. In *Proceedings of WSCLA 7th, UBC Working Papers in Linguistics 10*, pp.1-14. Vancouver, Ca: University of British Columbia.
- Borer, Hagit. 2005. *The normal course of events*. Oxford: Oxford University Press.
- Hale, Kenneth. 1989. The causative construction in Miskitu. In Jaspers, D. et al. (eds.) *Sentential Complementation and the Lexicon: Studies in Honour of Wim de Geest*. Foris Publications. Pp. 189-205.
- Hale, Kenneth. 1991. Misumalpan verb sequencing constructions. In Lefebvre, C. (ed.) *Serial Verbs: Grammatical, Comparative and Cognitive Approaches*. Amsterdam: John Benjamins. Pp. 1-35.
- Hale, Kenneth. 1997. The Misumalpan Causative Construction. In Bybee, Joan, John Haiman, and Sandra A. Thompson, eds. *Essays on Language Function and Language Type Dedicated to T. Givon*. Pp. 200-215. Amsterdam: John Benjamins.
- Hale, Kenneth. 1992. Subject Obviation, Switch Reference, and Control. In Richard K. Larson, Sabine Iatridou, Utpal Lahiri and James Higginbotham (eds), *Control and Grammar*, Studies in Linguistics and Philosophy, vol. 48, 51-77. Dordrecht: Kluwer Academic Publishers.
- Kratzer, Angelika. 1996. Severing the external argument from its verb. In Johan Rooryck & Laurie Zaring (eds), *Phrase structure and the lexicon*, 109–137. Dordrecht: Kluwer.
- Norwood, Susan. (1988/1997). *Gramática de la Lengua Sumu*. CIDCA. Managua, Nicaragua.

Elena E. Benedicto
Indigenous and Endangered Languages Lab
500 Oval Drive
Purdue University
West Lafayette, IN 47907
ebenedi@purdue.edu

Elizabeth Salomón
elisalomon12@yahoo.com