

# Chapter 10

## Friction

“A gem cannot be polished without friction, nor an individual perfected without trials.”

~ Lucius Annaeus Seneca (4 BC - 65 AD)

### 10.1 Overview

When two bodies are in contact, the forces of interaction between the two bodies can become complicated in terms of both their magnitudes and directions. Up to this point in this course, we have focused on “smooth” contact. A consequence of this assumption is that the two bodies can exert contact forces that are perpendicular, or normal, to the surface of contact. This reaction force has been referred to as the normal force of contact. For example, if a set of forces act on a block at rest on a fixed, smooth surface, then this surface reacts with a normal force  $N$ , as shown below. The block will begin to slide along the surface unless the net tangential component of the applied forces is zero.

A more realistic model of contact is one in which the bodies exert contact forces that have components that are both normal and tangent to the surface of contact. (Try pushing the palm of your hand along the surface of your desk. You can feel the desk reacting both perpendicular to and tangent to the desk surface.) Consider again the example of a set of forces acting on a block at rest on a fixed surface except now we will allow for a tangential component of reaction. We will refer to this tangential component of the total reaction force  $\vec{F}_R$  as being the “friction force”  $f$ . If this friction force is sufficiently large, the block can remain in equilibrium (“sticking”). Otherwise, the block will begin to slide.

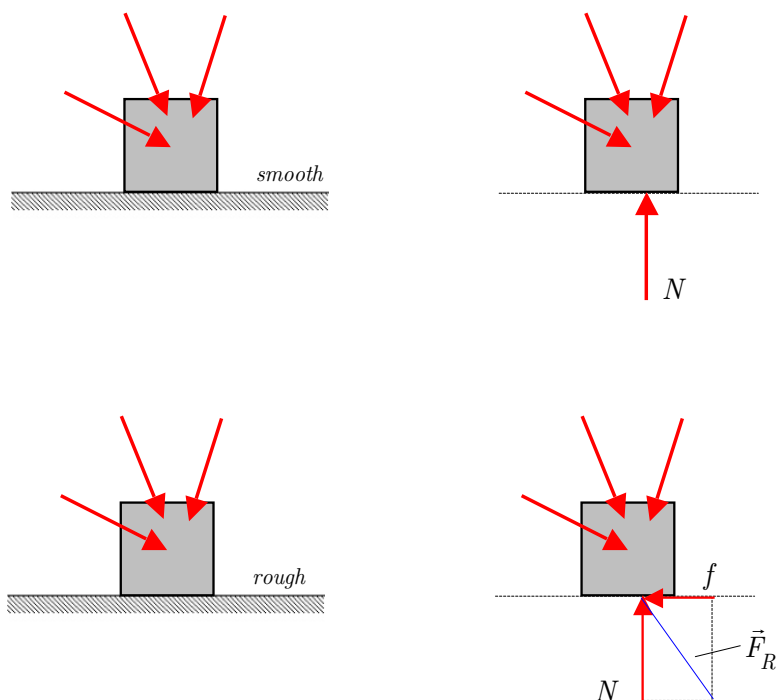

The actual mechanism of the friction force is quite complicated and is not fully understood. The current thinking is that friction results from microscopic irregularities on the contacting surfaces of the two bodies. In this course, we will not study friction at that level. Rather, we will employ some fundamental principles that give us a more macroscopic view of friction. In doing so, we will use the following two principles related to the magnitude and direction of friction forces:

- The magnitude of the friction force required for equilibrium is limited by a maximum value depending on the surface of contact. This magnitude is generally expressed in terms of the ratio  $f/N \leq (f/N)_{max}$ . For  $f/N > (f/N)_{max}$ , the two surface slip. The ratio  $(f/N)_{max}$  is known as the “coefficient of static friction”  $\mu_s$ . Therefore, we have  $f \leq \mu_s N$ , with the equality corresponding to “impending slipping”.
- Friction will always oppose the direction of slipping at the contacting surface. To determine this direction, consider how the system would move in the absence of friction with this known as the direction of “impending motion”.

If you can always remember the above two principles, you will do well in learning this material. We will remind you of these throughout our subsequent discussion.

Consider the following simple system made up of a block of weight  $W$  resting on a rough, horizontal surface. A horizontal force  $P$  is applied to the right on the block. The free body diagram of the block is shown in the figure below right. In this free body diagram  $f$  and  $N$  are the friction and normal components, respectively, of the reaction force of the ground on the block.

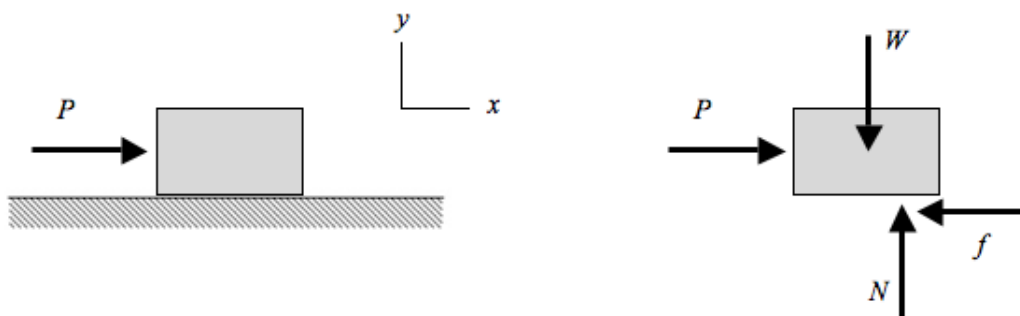

From this FBD, we have the following equilibrium equations:

$$\sum F_x = P - f = 0 \quad \rightarrow \quad f = P$$

$$\sum F_y = N - W = 0 \quad \rightarrow \quad N = W$$

From the first equation, we see that, as long as the block remains in equilibrium, the friction force is always equal to the applied force  $P$ . However, from the above discussion, we know that the friction force has a maximum value of  $f_{max} = \mu_s N$ , and when  $f = f_{max}$  the block will be in a state of “impending slipping” (still in equilibrium but on the verge of slipping).

For our current problem at hand, we see when  $P > f_{max} = \mu_s N$ , the block will slip. Once slipping occurs, what is the value of the friction force? This is where friction gets a little more complicated. Friction forces due to sliding depend on a lot of factors including the roughness of the surfaces, the amount of lubrication, speed of sliding, etc. One simple model that is commonly used is one in which the sliding friction force is less than that corresponding to impending slipping and is CONSTANT with speed. This relationship is written as  $f_{sliding} = \mu_k N$ , where  $\mu_k$  is the “coefficient of kinetic (or sliding) friction.”

The results of our discussion above are summarized in the following plot of friction force  $f$  vs. applied force  $P$ . This figure demonstrates that  $f$  follows a one-to-one relationship with  $P$  (straight line with slope of “1”) for  $P \leq \mu_s N$ . For  $P > \mu_s N$ , sliding commences and the friction force is a constant value of  $f = \mu_k N$  for all subsequent motion to the right.

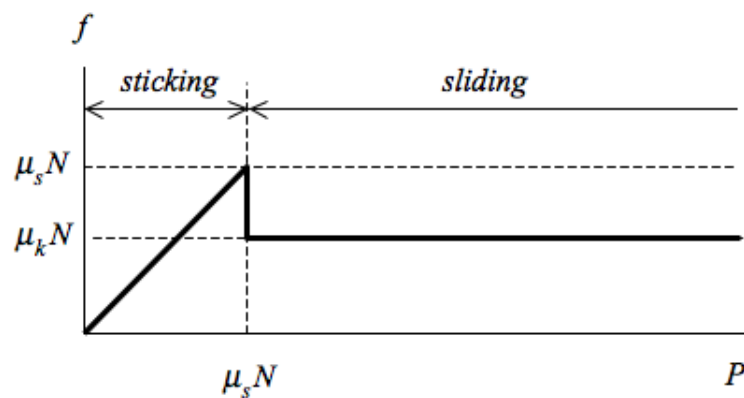

In summary, the force of friction is governed by the following important relations:

- **For sticking:**  $f \leq f_{max} = \mu_s N$ . The friction force is EQUAL to  $\mu_s N$  ONLY for the case of impending sliding.
- **For impending sliding:**  $f = \mu_s N$ .
- **For sliding:**  $f = \mu_k N$ .

REMEMBER THESE RESULTS!!

## 10.2 Dry friction and equilibrium

Let's repeat two important results from the preceding overview on friction that will be used in your equilibrium analysis:

- For a system in equilibrium, any friction force is governed by the following:  $f \leq f_{max} = \mu_s N$ . The friction force is EQUAL to  $\mu_s N$  ONLY for the case of impending sliding.
- Friction will always oppose the direction of slipping at the contacting surface. To determine this direction, consider how the system would move in the absence of friction with this known as the direction of "impending motion".

Consider the following steps (the OK method) for solving equilibrium problems with friction:

1. **FBDs.** Draw individual free body diagrams of each component in the system. Put some thought into this. We know that a force of friction on a body opposes the direction of impending motion. Carefully read the question and determine what is being asked. Consider how the system would move in the absence of friction; this will establish the directions of impending motion. Draw a friction force on the body to oppose the direction of impending motion at that surface.
2. **Equilibrium equations.** From your FBDs, write down the appropriate equations of equilibrium. Be careful that the signs on forces in these equations are consistent with the directions shown in your FBDs. Leave forces of friction as general forces of reaction at this stage; that is, do not substitute in any relationships of impending sliding here.
3. **Kinematics, constraints, and geometry.**
4. **Solve.** At this point, study your FBDs and equilibrium equations. Determine on which surfaces impending sliding will occur (as we will see later on with wedges and tipping/slipping problems, sliding will rarely occur simultaneously at all surfaces on complex problems). On these surfaces, set the friction force equal to their maximum value:  $f = f_{max} = \mu_s N$ . On all other surfaces, leave the friction forces as general forces of reaction.

Consider the following examples of equilibrium problems with friction.

**Example 10.2.1**

Consider the mechanism shown at a position for which  $\theta = 60^\circ$ . A CW torque  $T$  acts on member AB. The static coefficient of friction between the slider C and the horizontal surface is  $\mu_s = 0.5$ . Is the system in equilibrium? Ignore the weight of link BC and of the slider.

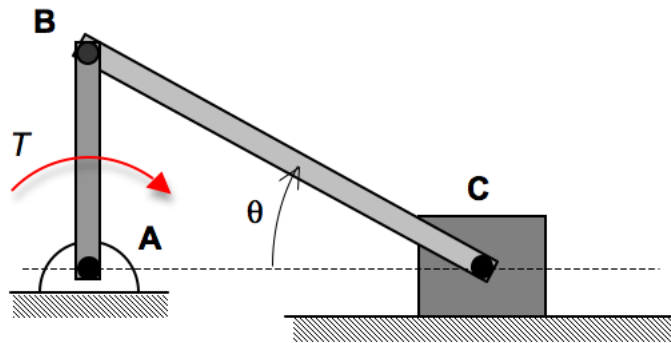

**Example 10.2.2**

An  $85\text{lb}$  force  $P$  is applied to a  $200\text{lb}$  block, with the block being stationary before the force is applied. Determine the magnitude and direction of the friction force  $f$  exerted by the horizontal surface on the block. The coefficients of static and kinetic friction are  $\mu_s = 0.5$  and  $\mu_k = 0.4$ , respectively.

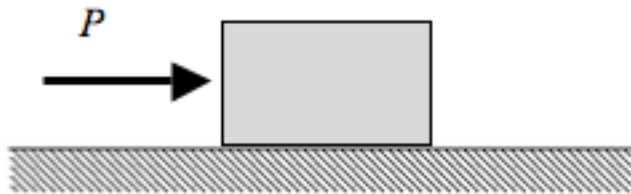

**Example 10.2.3**

The  $300lb$  crate with mass center at  $G$  is supported on the horizontal surfaces by a skid at  $A$  and a roller at  $B$ . A force of  $P = 60lb$  is required to initiate motion of the crate. Determine the coefficient of static friction at  $A$ .

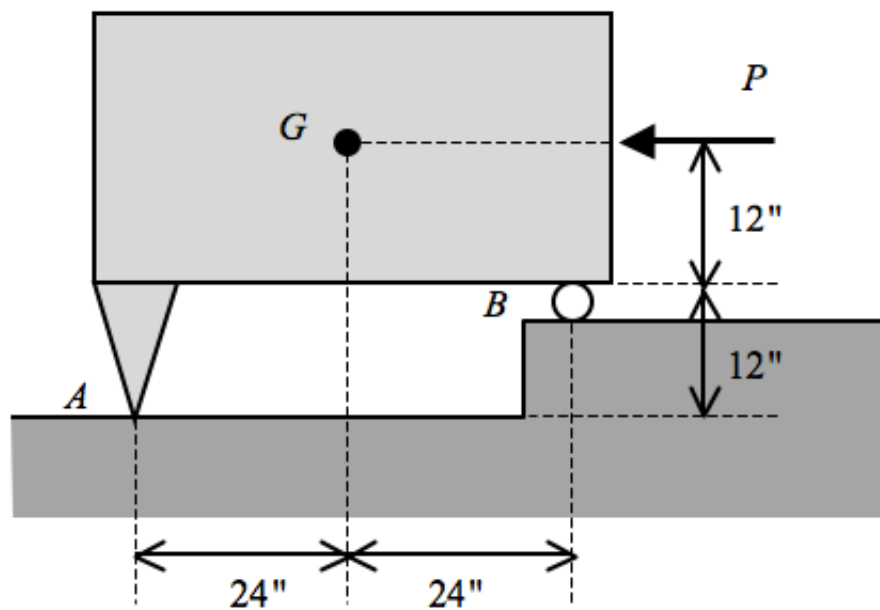



**Example 10.2.4**

Block A has a weight of  $100lb$ . Determine the range of weights  $W$  of block B for which the system is in equilibrium.

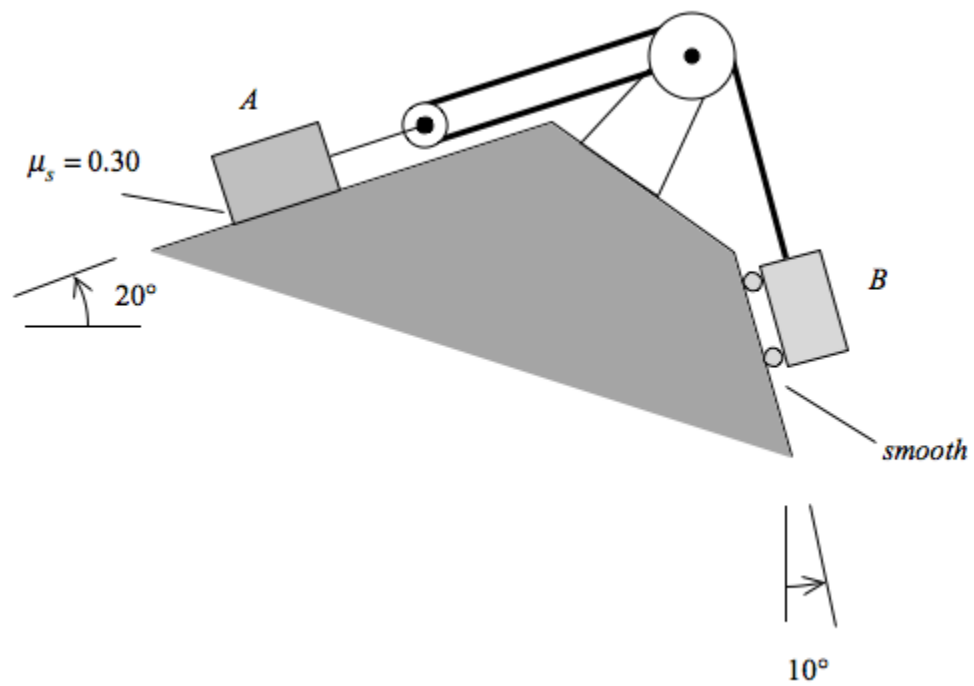

**Example 10.2.5**

The block and bar AB each have a mass of  $m$ . Determine the magnitude of the force  $P$  required to initiate motion of the block. Use  $m = 3kg$ ,  $\theta = 30^\circ$ ,  $\mu_s = 0.6$  and  $\mu_k = 0.5$ .

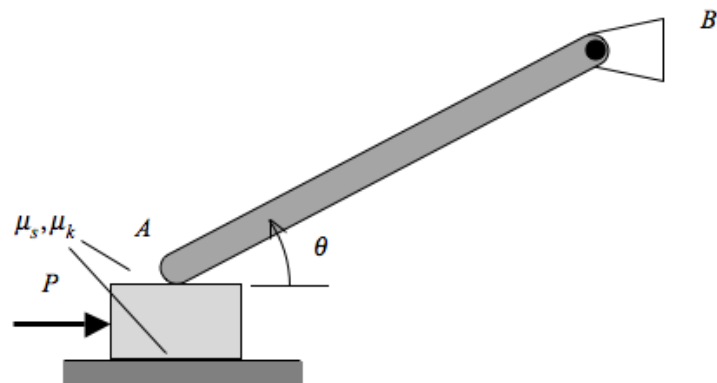

## 10.3 Wedges

Wedges are important to many applications. In particular, they are a good way to position objects with very high accuracy. One of the best is to position lasers for applications such as LASIK surgery. Imagine someone firing a laser at your cornea without positioning it perfectly. Not a pleasant thought.

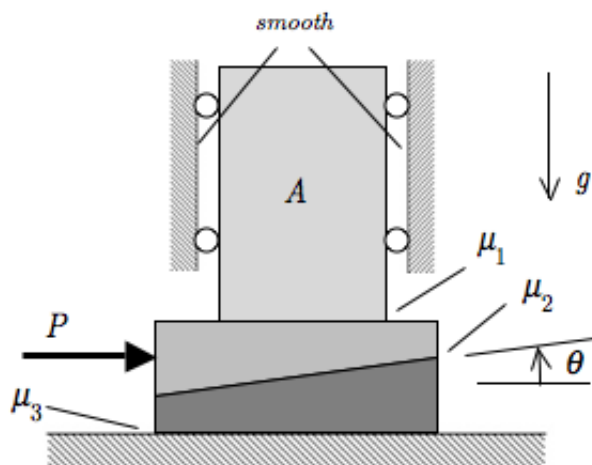

Before tackling the wedge positioning problem above, let's consider first the simpler example shown below. Here we have a block of weight  $W$  being held in position on a rough incline with a wedge. In general, a horizontal force  $P$  is acting on the wedge to the right in order to hold the wedge in position. Our goal with this example is to determine the range of positioning force values  $P$  that is required to hold the wedge and block in equilibrium.

Consider the following assumptions:

- Assume that the weight of the wedge is small compared to the weight of the block.
- Assume that the physical dimensions of the wedge are not important. We will be concerned here with understanding the sizes of the friction forces acting on the wedge. The location of the friction forces on the contacting surfaces will not be of interest to us.
- Assume that for all analysis the system of the block and wedge are in static equilibrium. We will consider situations of "impending motion" which will imply that the system is on the verge of moving, however, the system will still be in equilibrium.

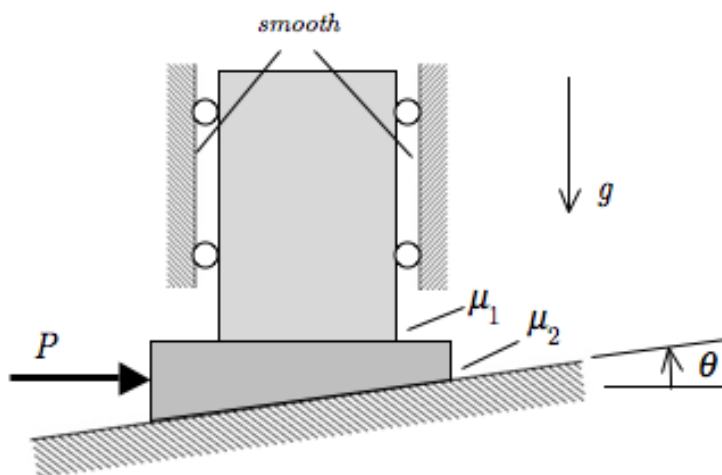

Now, let's consider the influence of the size of the wedge force  $P$  on the state of equilibrium for the system.

- Case A. If the magnitude of  $P$  is sufficiently large, the wedge will tend to slide UP the incline. In this case we consider  $P = P_{max}$  as being the largest value of  $P$  for which the system can be in equilibrium and a situation in which the "impending motion" of the wedge is up the incline.
- Case B. If the size of  $P$  is sufficiently small, the wedge will tend to slide DOWN the incline (i.e., the wedge will be squeezed out from under the block due to the weight of the block). In this case we consider  $P = P_{min}$  as being the smallest value of  $P$  for which the system can be in equilibrium and a situation in which the "impending motion" of the wedge is down the incline.

Therefore, for  $P_{min} \leq P \leq P_{max}$ , the system will be in equilibrium, where  $P_{max}$  and  $P_{min}$  are found from Cases A and B, respectively.

We will consider Cases A and B individually in the following analysis.

**Case A:**  $P = P_{max}$

Recall that for  $P = P_{max}$ , the impending motion of the wedge is up the incline. Since friction opposes the direction of impending motion, the friction forces  $f_1$  and  $f_2$  on the wedge are directed as shown in the FBDs below. From Newton's third law, the friction force of the wedge on the block is  $f_1$  and pointing to the right.

**FBDs for Case A**

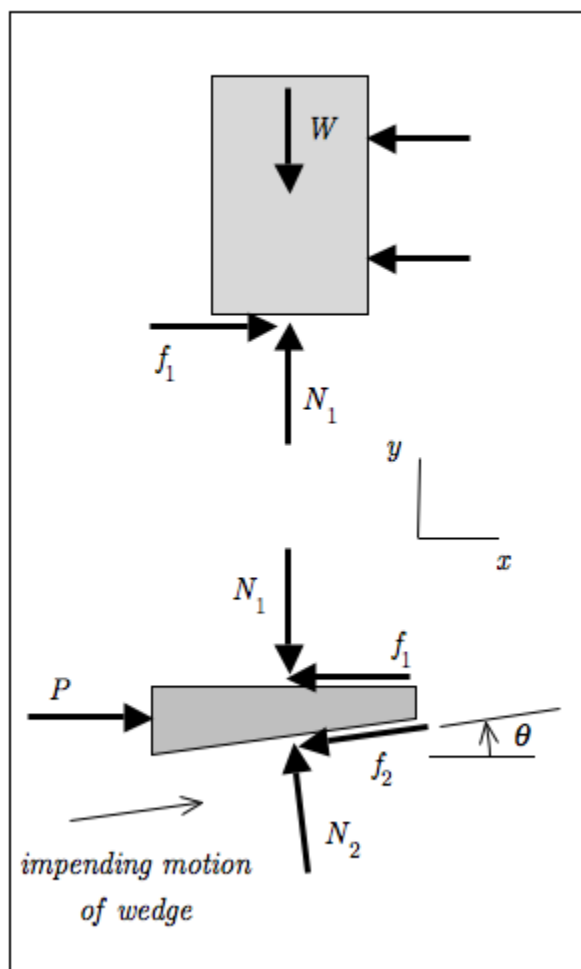

From the above FBDs, we can write the following equilibrium equations for the wedge and block:

$$\begin{aligned} \text{Block :} \quad & \sum F_y = -W + N_1 = 0 \\ \text{Wedge :} \quad & \sum F_y = -N_1 - f_2 \sin \theta + N_2 \cos \theta = 0 \\ & \sum F_x = P - f_1 - f_2 \cos \theta - N_2 \sin \theta = 0 \end{aligned}$$

Since we are considering “impending motion”, the friction forces  $f_1$  and  $f_2$  are both at their maximum values (slipping must occur at both surfaces for the wedge to move):  $f_1 = \mu_1 N_1$  and  $f_2 = \mu_2 N_2$ . Substituting these friction forces into the equilibrium equations and solving for  $P = P_{max}$  gives:

$$N_1 = W$$
$$N_2 = \frac{N_1}{-\mu_2 \sin\theta + \cos\theta} = \frac{W}{-\mu_2 \sin\theta + \cos\theta}$$

$$P_{max} = \mu_1 N_1 + (\mu_2 \cos\theta + \sin\theta) N_2$$
$$= \left[ \mu_1 + \left( \frac{\mu_2 \cos\theta + \sin\theta}{-\mu_2 \sin\theta + \cos\theta} \right) \right] W$$

Therefore, for  $P > P_{max}$ , the wedge will slide UP the incline, and the block will be lifted.

**Case B:**  $P = P_{min}$ 

Recall that for  $P = P_{min}$ , the impending motion of the wedge is down the incline. Since friction opposes the direction of impending motion, the friction forces  $f_1$  and  $f_2$  on the wedge are directed as shown in the FBDs below. From Newton's third law, the friction force of the wedge on the block is  $f_1$  pointing to the left.

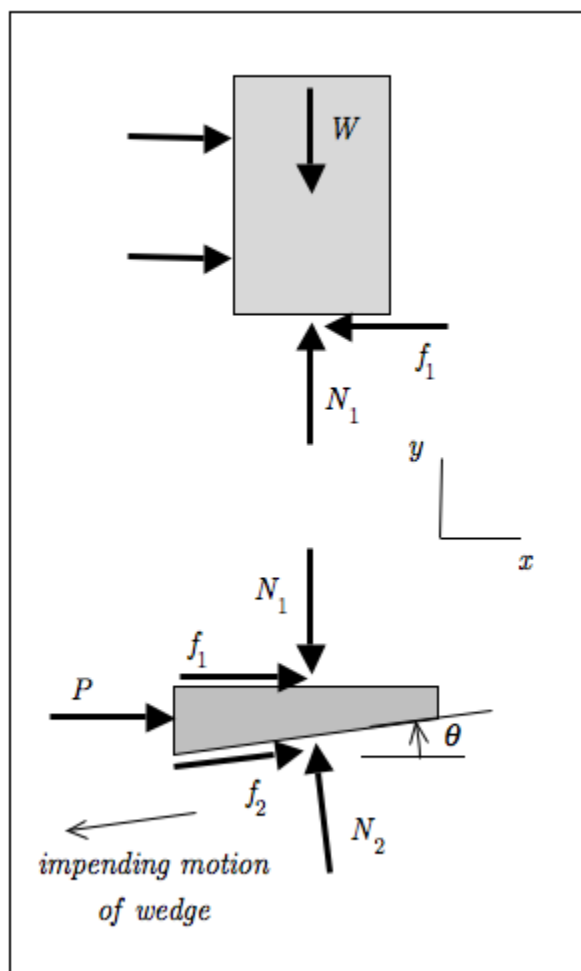
**FBDs for Case B**

From the above FBDs, we can write the following equilibrium equations for the wedge and block:

$$\begin{aligned}
 \text{Block :} \quad & \sum F_y = -W + N_1 = 0 \\
 \text{Wedge :} \quad & \sum F_y = -N_1 + f_2 \sin \theta + N_2 \cos \theta = 0 \\
 & \sum F_x = P + f_1 + f_2 \cos \theta - N_2 \sin \theta = 0
 \end{aligned}$$

Since we are considering “impending motion”, the friction forces  $f_1$  and  $f_2$  are both at their maximum values (since slipping must occur at both surfaces in order for the wedge to move):  $f_1 = \mu_1 N_1$  and  $f_2 = \mu_2 N_2$ . Substituting these friction forces into the equilibrium equations and solving for  $P = P_{min}$  gives:

$$\begin{aligned} N_1 &= W \\ N_2 &= \frac{N_1}{\mu_2 \sin\theta + \cos\theta} = \frac{W}{\mu_2 \sin\theta + \cos\theta} \\ P_{min} &= -\mu_1 N_1 + (-\mu_2 \cos\theta + \sin\theta) N_2 \\ &= \left[ -\mu_1 + \left( \frac{-\mu_2 \cos\theta + \sin\theta}{\mu_2 \sin\theta + \cos\theta} \right) \right] W \end{aligned}$$

Therefore, for  $P < P_{min}$ , the wedge will slide down the incline, and the block will be lowered as it squeezes out the wedge.

In summary, the wedge/block system will be in equilibrium over a range of forces  $P$  applied to the wedge. In particular, the system is in equilibrium if:

$$P_{min} \leq P \leq P_{max} \quad \Rightarrow \quad \left[ -\mu_1 + \left( \frac{-\mu_2 \cos\theta + \sin\theta}{\mu_2 \sin\theta + \cos\theta} \right) \right] W \leq P \leq \left[ \mu_1 + \left( \frac{\mu_2 \cos\theta + \sin\theta}{-\mu_2 \sin\theta + \cos\theta} \right) \right] W$$

Let's consider now some numerical values for  $\mu_1$ ,  $\mu_2$  and  $\theta$ :

- First let's use:  $\mu_1 = \mu_2 = 0.1$  and  $\theta = 20^\circ$ . With this, we have:

$$P_{max} = \left[ 0.1 + \left( \frac{0.1 \cos 20^\circ + \sin 20^\circ}{-0.1 \sin 20^\circ + \cos 20^\circ} \right) \right] W = 0.581W$$

$$P_{min} = \left[ -0.1 + \left( \frac{-0.1 \cos 20^\circ + \sin 20^\circ}{0.1 \sin 20^\circ + \cos 20^\circ} \right) \right] W = 0.155W$$

Therefore, for  $0.155W \leq P \leq 0.581W$  the system is in equilibrium.

- Next let's use:  $\mu_1 = \mu_2 = 0.2$  and  $\theta = 10^\circ$ . With this, we have:

$$P_{max} = \left[ 0.2 + \left( \frac{0.2 \cos 10^\circ + \sin 10^\circ}{-0.2 \sin 10^\circ + \cos 10^\circ} \right) \right] W = 0.590W$$

$$P_{min} = \left[ -0.2 + \left( \frac{-0.2 \cos 10^\circ + \sin 10^\circ}{0.2 \sin 10^\circ + \cos 10^\circ} \right) \right] W = -0.223W$$



Therefore, for  $-0.223W \leq P \leq 0.590W$  the system is in equilibrium. Note that for this case  $P_{min} < 0$  – what is the significance of the negative sign on  $P_{min}$ ? This says that in order to initiate movement of the wedge down the incline we need to reverse the direction of the applied force  $P$ ; that is, we need to PULL on the wedge to the left in order to lower the block. Stated in a different way, the system is in equilibrium when  $P = 0$ . The friction forces are sufficiently large on their own to hold the block in position. For this set of parameters, the wedge is said to be “self-locking”.



wedges:

$$\begin{aligned}
 \text{Block :} & \quad \sum F_y = -W + N_1 = 0 \\
 \text{Top wedge :} & \quad \sum F_y = -N_1 - f_2 \sin\theta + N_2 \cos\theta = 0 \\
 & \quad \sum F_x = P - f_1 - f_2 \cos\theta - N_2 \sin\theta = 0 \\
 \text{Lower wedge :} & \quad \sum F_y = N_3 + f_2 \sin\theta - N_2 \cos\theta = 0 \\
 & \quad \sum F_x = -f_3 + f_2 \cos\theta + N_2 \sin\theta = 0
 \end{aligned}$$

As a result of a sufficiently large applied force  $P$ , we have two possible situations for impending motion:

- The upper wedge will move to the right and the lower wedge will remain stationary. That is, the upper wedge will slip relative to both the block and the lower wedge, with the lower wedge sticking to ground. As a result, the block will be lifted.
- Both the upper and lower wedges will move to the right. That is, the upper wedge will slip relative to the block and stick to the lower wedge, with the lower wedge sliding on the ground. In this case, the block will not be lifted.

Unfortunately, we have no way of knowing in advance as to which situation will occur. What we will do is “assume” a scenario and solve for the maximum loading  $P$  allowed for equilibrium. Since an assumption is needed to solve, we need to check our answers when we are done in order to determine the validity of the assumption.

Suppose here that we assume the first case: impending slipping between the two wedges but no slipping between the lower wedge and the ground. For this assumption we have:  $f_1 = \mu_1 N_1$  and  $f_2 = \mu_2 N_2$ , along with  $f_3 \neq \mu_3 N_3$ . Substituting these friction forces into the equilibrium equations for the block and upper wedge, and solving for  $P = P_{max}$  gives:

$$\begin{aligned}
 N_1 &= W \\
 N_2 &= \frac{N_1}{-\mu_2 \sin\theta + \cos\theta} = \frac{W}{-\mu_2 \sin\theta + \cos\theta} \\
 P_{max} &= \mu_1 N_1 + (\mu_2 \cos\theta + \sin\theta) N_2 \\
 &= \left[ \mu_1 + \left( \frac{\mu_2 \cos\theta + \sin\theta}{-\mu_2 \sin\theta + \cos\theta} \right) \right] W
 \end{aligned}$$

This equation gives of the maximum load  $P$  that can be applied and still have the system in equilibrium under the assumption that the lower wedge does STICKS on the ground. How do we check this assumption?

Note that we have not yet used the equilibrium equations above for the lower wedge. Using our assumption of sliding between the two wedges,  $f_2 = \mu_2 N_2$ , these two equations become:

$$N_3 = (-\mu_2 \sin\theta + \cos\theta) N_2$$

$$f_3 = (\mu_2 \cos\theta + \sin\theta) N_2$$

If the lower wedge sticks on the ground, then  $f_3 < \mu_3 N_3$ , or:

$$\mu_3 > \frac{f_3}{N_3} = \frac{\mu_2 \cos\theta + \sin\theta}{-\mu_2 \sin\theta + \cos\theta}$$

If the above inequality holds true, then our original assumption was correct, and the value found for  $P_{max}$  is truly the maximum applied force  $P$  allowed for the system to remain in equilibrium. If this inequality does not hold true, then our assumption of slipping between the two wedges was incorrect. In case, we (unfortunately) must rework the problem assuming that the lower wedge slips ( $f_3 = \mu_3 N_3$ ) and that the two wedges stick ( $f_2 \neq \mu_2 N_2$ ).

To see how this works, we will use the following:  $\mu_1 = \mu_2 = 0.1$ ,  $\mu_3 = 0.5$  and  $\theta = 20^\circ$ . From the above, we have (using the assumption of sticking between the lower wedge and ground):

$$P_{max} = \left[ 0.1 + \left( \frac{0.1 \cos 20^\circ + \sin 20^\circ}{-0.1 \sin 20^\circ + \cos 20^\circ} \right) \right] W = 0.581W$$

Now, checking that assumption:

$$\begin{aligned} \frac{f_3}{N_3} &= \frac{\mu_2 \cos\theta + \sin\theta}{-\mu_2 \sin\theta + \cos\theta} \\ &= \frac{0.1 \cos 20^\circ + \sin 20^\circ}{-0.1 \sin 20^\circ + \cos 20^\circ} = 0.481 \end{aligned}$$

Since  $\mu_3 = 0.5 > f_3/N_3$ , our assumption of sticking between the lower wedge and ground is valid. Therefore, an applied force  $P > P_{max} = 0.581W$  will lift the block.

**Discussion: wedges with friction**

1. As we have seen in our earlier work with friction, friction forces are, in general, forces of reaction. As general forces of reaction, the direction of the friction forces can be found by assuming the direction when drawing your FBDs (while abiding by Newton's third law of action and reaction). In that case, the direction is found from your solution. However, when considering IMPENDING motion ( $f = \mu_s N$ ) you MUST know the direction of the friction force at the time of drawing your FBDs. You cannot rely on the mathematics to determine the correct direction.
2. In our work here on wedges, we are typically determining the maximum and minimum applied forces for equilibrium. Since these situations result in impending motion, you must know the direction of friction forces when you draw your FBDs for your system.
3. Before starting a solution for problems involving wedges, carefully study the problem statement. What question is being asked? From the problem statement, you should be able to determine the directions of impending motion. Only then, can you draw your FBDs and solve.
4. For problems involving more than one wedge, you will likely encounter a situation of not knowing in advance on which surfaces you expect impending slip. For these problems, make an assumption as to the surfaces on which impending slip will occur. On all other surfaces, leave friction forces as regular forces of reaction. After solving, then check your assumption. If your assumption was incorrect, you need to rework the problem based on what you learned from your original assumption.

**Example 10.3.1**

Determine the smallest horizontal force  $P$  required to pull out wedge A. The crate has a weight of  $300lb$  and the coefficient of static friction at all contacting surfaces is  $\mu_s = 0.3$ . Neglect the weight of the wedge.

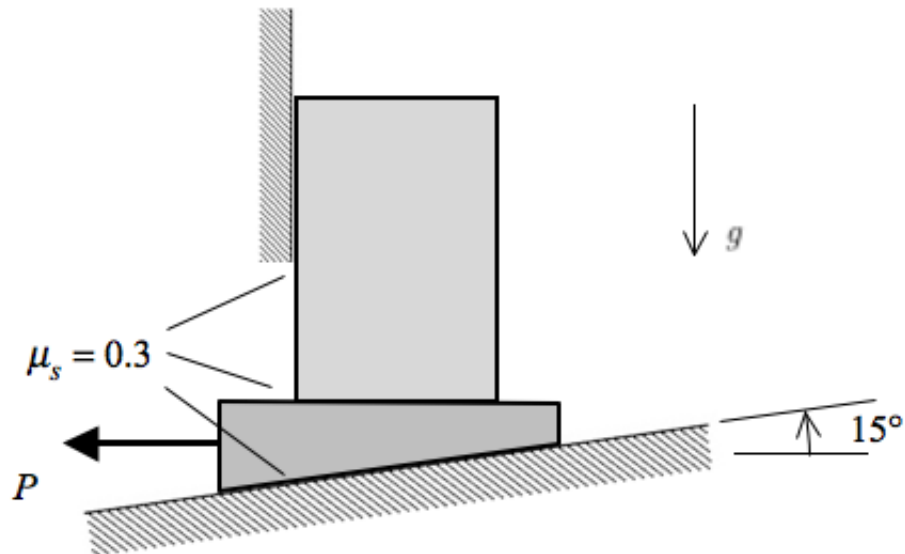

**Example 10.3.2**

The coefficient of static friction on both sides of the wedge is  $\mu_s = 0.2$ . Is the wedge self-locking? Neglect the weight of the wedge and bar.

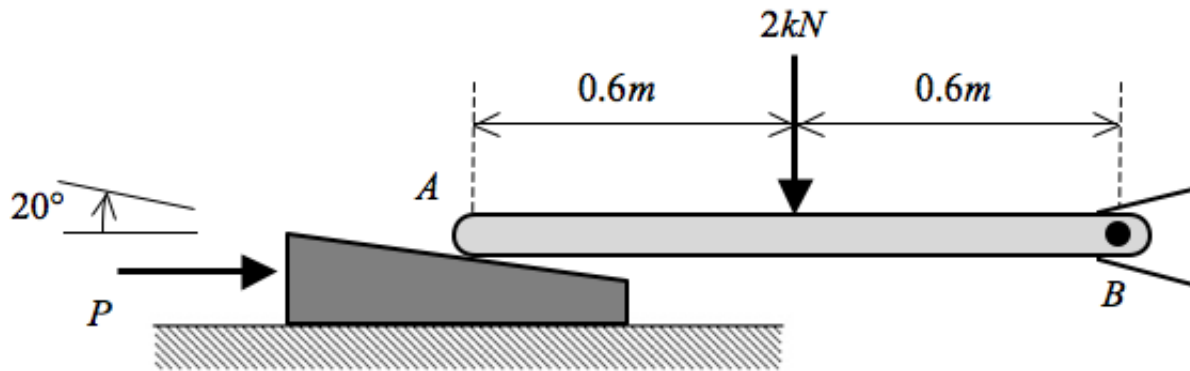

**Example 10.3.3**

Determine the smallest horizontal force  $P$  required to lift the  $100\text{kg}$  cylinder. The coefficient of static friction at all surfaces is  $\mu_s = 0.3$ . Neglect the weight of the wedge.

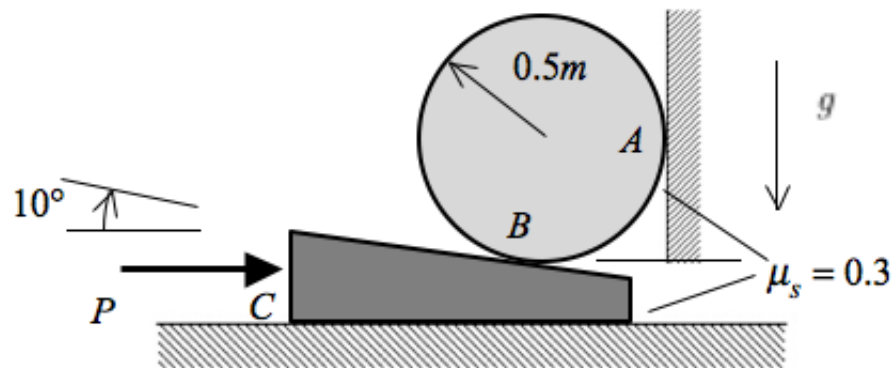



## 10.4 Slipping and Tipping

Up to this point in our discussion of problems with friction, impending motion in a given system resulted from applied forces that create slipping at certain contacting surfaces. Recall that impending motion occurs at a surface where the friction force  $f$  and the normal force  $N$  are related by:  $f = f_{max} = \mu_s N$ .

In this section of the textbook, we will study a different kind of problem where impending motion in frictional systems can result from either slipping (as described above) or from a pair of interfacing surfaces losing contact with each other. This second situation will be referred to as “tipping”.

As an introduction to this topic, consider the case shown below of a block of weight  $W$  and center of mass at  $G$  that is resting on a rough horizontal surface (with coefficient of static friction  $\mu_s$ ). A horizontal force  $P$  is applied to the block at vertical distance of  $h$  above the rough surface.

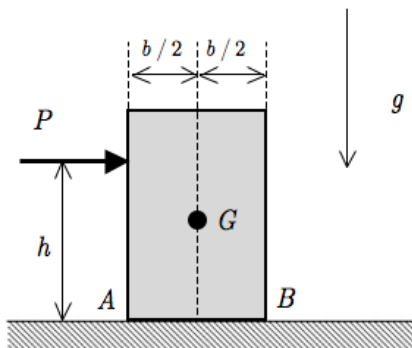

In the absence of the applied force  $P$  the normal reaction force on the block from the ground is immediately below the center of mass  $G$ , as shown below left. However, with the application of the force  $P$ , the point of application for the normal and friction forces has moved a distance of  $d$  to the right at point  $C$ , as shown in the figure below right. How far to the right have these forces moved? That is, what is the value for  $d$ ? To see this, we will write down a moment equilibrium equation about point  $C$ :

$$\sum M_C = Wd - Ph = 0 \quad \Rightarrow \quad d = \frac{P}{W}h$$

From this we see that these contact forces move to the right as either  $P$  or  $h$  is increased. When  $P = 0$ ,  $d = 0$  and the normal force  $N$  is directly below  $G$ , as described earlier.

What happens when this distance  $d$  falls outside of the contact region of the block with the ground (that is, when  $d > b/2$ )? The answer is that the block can no longer remain in

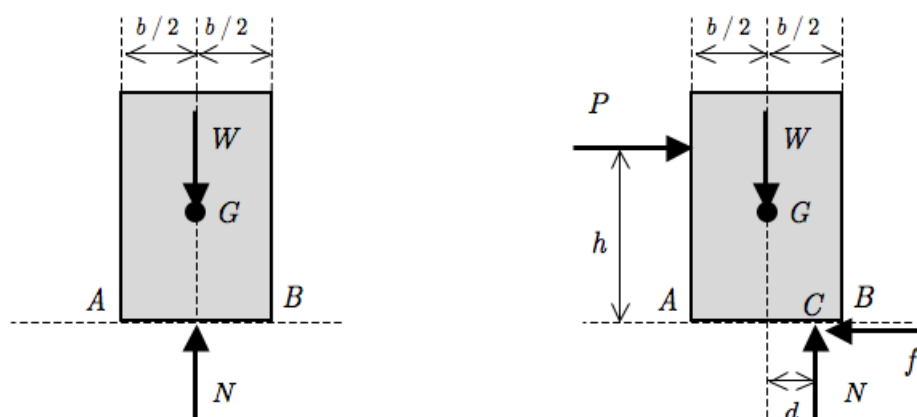

equilibrium in rotation; it has "tipped" about corner B of the block.

Let us now look at the force equilibrium equations for the block:

$$\sum F_x = P - f = 0 \quad \Rightarrow \quad P = f$$

$$\sum F_y = N - W = 0 \quad \Rightarrow \quad N = W$$

From this we see that the block can no longer remain in equilibrium if  $P = f > \mu_s N (= \mu_s W)$  since, for this case, the block will slip on the horizontal surface.

We are now faced with the question as to whether the block will tend to tip or to slip first as the applied load  $P$  is increased. How do we answer that question?

There are many ways to deal with impending motion problems; those that require you to determine whether an object slips or tips. Here we will illustrate two of them.

### Method 1

1. Assume tipping and solve for the force required to cause impending motion due to tipping.
2. Assume slipping and solve for the force required to cause impending motion due to slipping.
3. Compare the forces you obtained in each step. From these two answers choose the one that satisfies conditions of equilibrium. If the force that you are seeking initiates

motion, then choose the smaller of the two. If the force that you are seeking prevents motion, then choose the larger of the two (since you want to prevent both tipping and slipping).

### Method 2

1. Assume tipping and solve for the force required to cause impending motion due to tipping.
2. Check to see how the friction force required for tipping compares to the maximum that can be generated at the surface.
3. If the friction force required for tipping is less than the maximum possible, the object tips and the problem is over. If it is greater than the maximum possible, it must have slipped.
4. If the object slips, you must solve that problem to obtain the force required to cause slipping motion.

The advantage of Method 1 is that it is the most straight forward, but it always requires you to solve both versions of the problem. Method 2 often saves time, but requires a little more logic. There are other methods that can be used, but these are the most straight forward.

In summary, do not memorize the above results for the example of the block with the horizontal applied force. Problems that you will face will not be that simple, and these results will not apply there. Instead, follow either of the above two methods. An accurate FBD along with the full set of equilibrium equations are the critical first steps in your solution.

### Special case

In some problems, the contacting surface will not be continuous, but rather at two discrete points. Consider the block shown below with small feet at corners A and B. The free body diagram of the block now has normal and friction forces at both A and B, as shown in the figure below right.

For this case,

- If the block is in a state of impending slipping, then we have  $f_A = \mu_s N_A$  AND  $f_B = \mu_s N_B$ , where  $N_A > 0$  and  $N_B > 0$ .

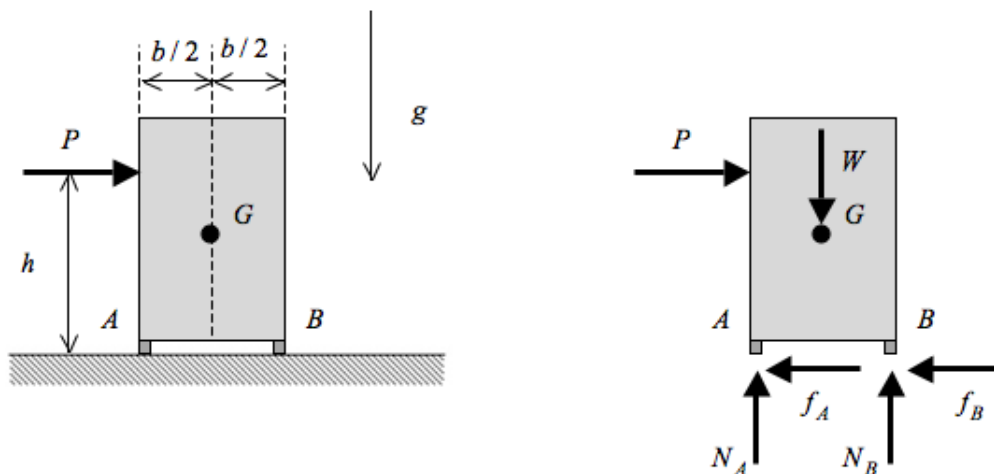

- If the block is in a state of impending tipping, then we have  $N_A = f_A = 0$  along with  $f_B \neq \mu_s N_B$  and  $N_B > 0$ .

The rest of the process for determining tipping vs. slipping is exactly the same as in the previous example of having a flat contact along the bottom of the block.

**Example 10.4.1**

The block has a weight of  $W = 200N$ . The coefficient of static friction between the block and the rough horizontal surface is known to be  $\mu_s = 0.5$ .

1. If  $\theta = 0$ , what is the minimum force  $P$  required to initiate movement of the block? Will the resulting motion be tipping or slipping?
2. If  $\theta = 40^\circ$ , what is the minimum force  $P$  required to initiate movement of the block? Will the resulting motion be tipping or slipping?

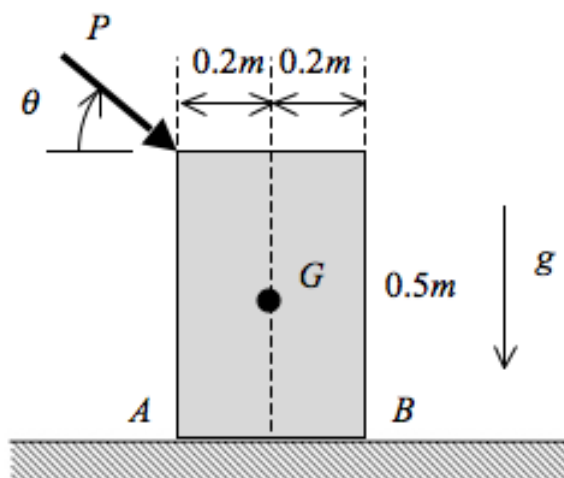

**Example 10.4.2**

A  $60\text{kg}$  cabinet whose center of mass is at point  $G$  is supported by small feet at  $A$  and  $B$ . The coefficients of static friction at  $A$  and  $B$  are  $\mu_A = \mu_B = 0.75$ . Determine the largest force  $P$ , parallel to the incline that can act on the cabinet and not have the cabinet move. Is the impending motion of the cabinet slipping or tipping?

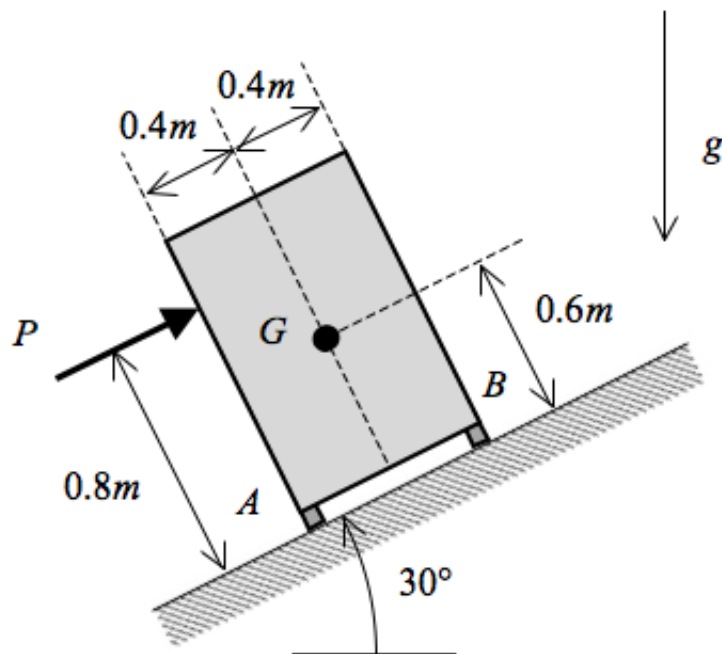

**Example 10.4.3**

A  $25\text{kg}$  door is mounted on a horizontal rail at sliders A and B. The coefficients of static friction at A and B are  $\mu_A = \mu_B = 0.15$ . The door handle C is pulled to the right to open the door. Determine the minimum force  $P$  acting at the handle in order to move the door. Use  $d = 2\text{m}$ . Is the impending motion of the door slipping or tipping?

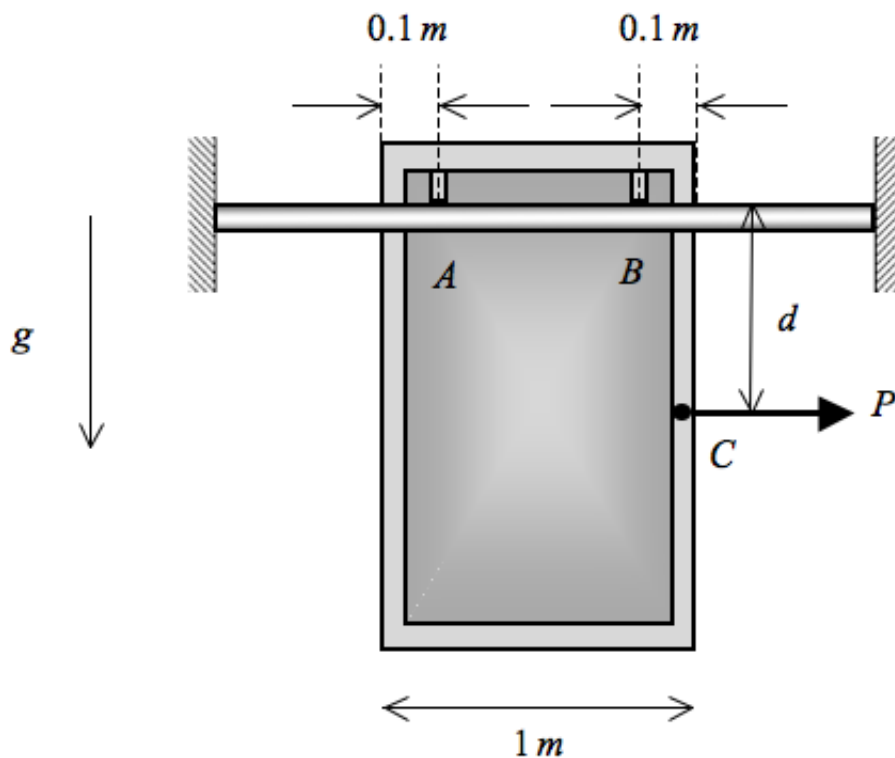

**Example 10.4.4**

Here you should see two stacked boxes. The top box has a mass of 40 kg and the bottom box has a mass of 35 kg. The coefficient of friction between the top and bottom boxes is 0.8 and the coefficient of friction between the bottom box and the ground is 0.68. Determine the force at which motion occurs. Do the boxes move together or independently? Do they tip or slip?

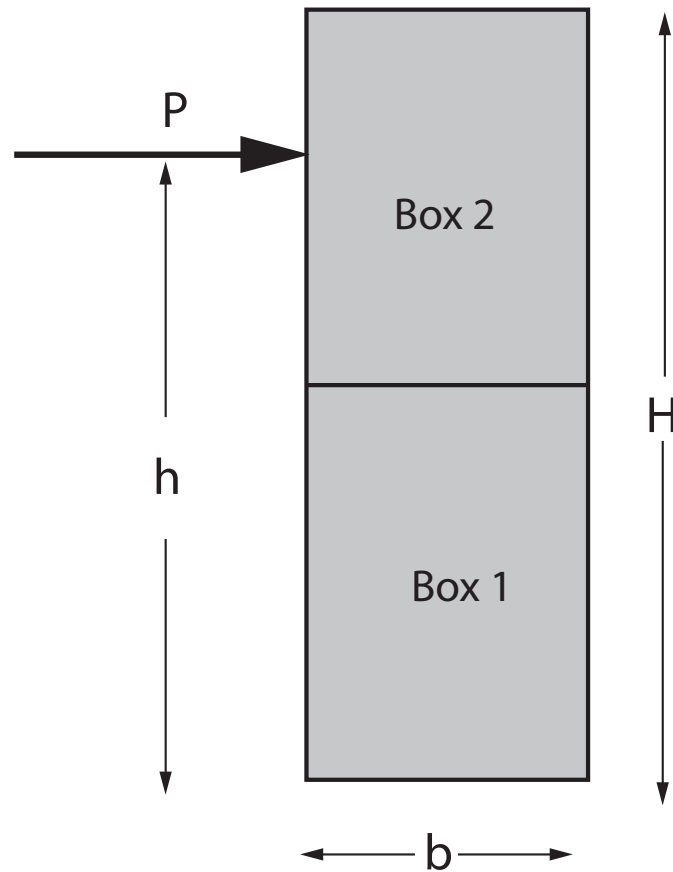



## 10.5 Belt Friction

Any time a belt, cable, or rope is wrapped around a rough cylinder (or non-ideal pulley) friction develops at the interface. Up to this point in the course, we have ignored the influence of friction for cable being pulled over pulleys. With the assumption that the pulley is smooth, we have concluded that the pulley does not alter the tension in the cable. Here we will now address the question as to how this friction produces a tension difference as the cable is wrapped around a non-ideal (rough) stationary drum. In order to determine the relationship for this tension difference, it is necessary to build up a mathematical model that utilizes differential elements as described in the following.

Consider the situation shown in the figure below left where we have a section of a belt pulled over a rough, stationary circular drum. The tensions at the ends of the belt are  $T_1$  at  $\theta = 0$  and  $T_2$  at  $\theta = \beta$ , where  $\beta$  is the total angle of wrap for the belt. For the sake of the mathematical development that follows, it is assumed that  $T_1 > T_2$ .

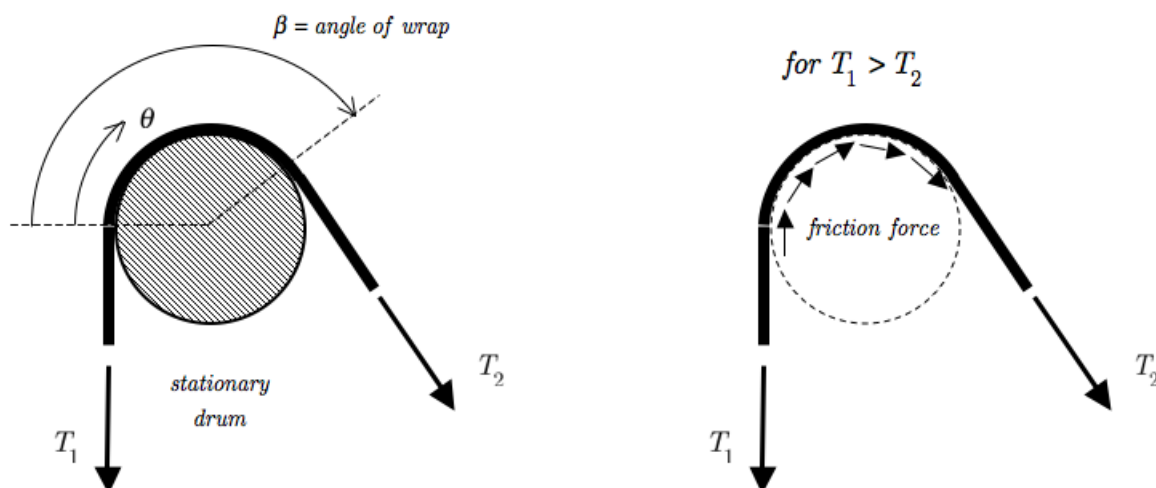

Since we have assumed  $T_1 > T_2$ , the impending motion of the belt on the drum is toward the higher tension end where the tension is  $T_1$ . The friction force on the belt by the drum will oppose the direction of impending slip; therefore, the distributed friction force on the belt will be as shown in the figure below right.

A free body diagram for a differential section of the belt in a state of impending slipping on the drum is shown in the following figure. This figure shows four forces acting on the section of the belt: the tensions  $T(\theta)$  and  $T(\theta + d\theta)$ , the normal force  $dN$  and the friction force  $df = \mu dN$ . It is important to note that the direction of the friction force is drawn to

oppose the direction of impending sliding of the section of the belt.

**FBD for differential section of belt**

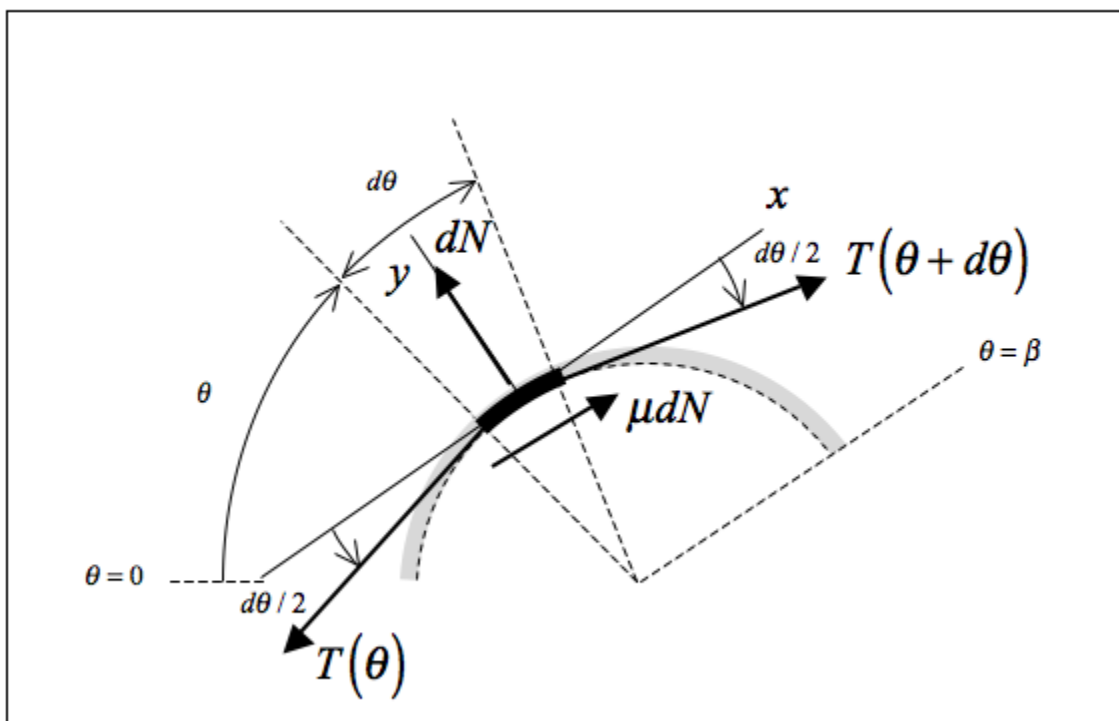

Summing forces acting on the belt section gives:

$$\sum F_x = T(\theta + d\theta)\cos(d\theta/2) - T(\theta)\cos(d\theta/2) + \mu dN = 0$$

$$\sum F_y = -T(\theta + d\theta)\sin(d\theta/2) - T(\theta)\sin(d\theta/2) + dN = 0$$

Since  $d\theta$  is of differential (small) size,  $\sin(d\theta/2) \rightarrow d\theta/2$  and  $\cos(d\theta/2) \rightarrow 1$ . Therefore, the above equilibrium equations become:

$$T(\theta + d\theta) = T(\theta) - \mu dN \quad \rightarrow \quad dN = -\frac{dT}{\mu}$$

$$-\frac{dT}{\mu} = [T(\theta + d\theta) + T(\theta)]\frac{d\theta}{2} = [T(\theta) - \mu dN + T(\theta)]\frac{d\theta}{2} = T d\theta - \frac{1}{2}dT d\theta$$

Since  $dT$  and  $d\theta$  are differential quantities,  $dT d\theta \approx 0$ . Therefore,

$$\begin{aligned} -\frac{dT}{\mu} &= T d\theta & \Rightarrow \\ -\frac{dT}{T} &= \mu d\theta \\ -\int_{T_1}^{T_2} \frac{dT}{T} &= \mu \int_0^\beta d\theta \\ \ln\left(\frac{T_1}{T_2}\right) &= \mu\beta & \Rightarrow & \quad \frac{T_1}{T_2} = e^{\mu\beta} \end{aligned}$$

**Discussion: cable/belt friction**

1. Recall that the above equation relating  $T_1/T_2$  to  $\mu$  and the angle of belt wrap  $\beta$

$$\frac{T_1}{T_2} = e^{\mu\beta}$$

was developed assuming impending slip between the belt and drum. It is NOT valid for a general situation of equilibrium.

2. You must know on which side of the drum does the belt have the highest tension before applying the above equation. That tension was named  $T_1$ , and it MUST appear in the numerator of the fraction on the left hand side of the above equation. Typically, you can determine the high tension side of the belt by reading the question and determining the direction of impending motion for the belt.  $T_1$  is the tension on the impending motion end of the belt. You need to put some thought on the direction of impending motion at the start of the problem.
3. The above equation shows that the ratio of tensions  $T_1/T_2$  increases exponentially with the angle of belt wrap  $\beta$ , where  $\beta$  is to be given in radians.

**Example 10.5.1**

The coefficient of static friction between the rope and the drum is known to be  $\mu_s = 0.5$ . Block B weighs  $W_B = 100\text{Newtons}$ . Determine the range of weights for block A so that the system remains in equilibrium.

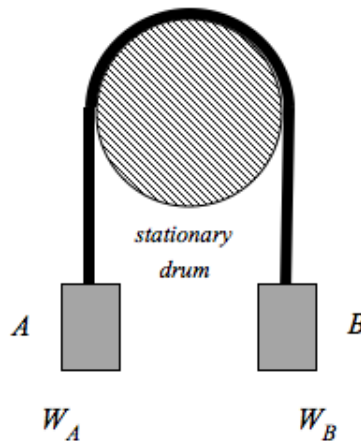

**Example 10.5.2**

During a particular rescue mission, a rescue worker weighing  $W = 180\text{lbs}$  is to be raised and lowered over the edge of a cliff. The rope attached to the worker is wrapped over  $90^\circ$  of the cliff's edge and a one full wrap around a vertical post at the top of the cliff.

1. Determine the minimum force  $P$  required to hold the rescue worker in equilibrium.
2. Determine the minimum force  $P$  required to initiate upward motion of the rescue worker.

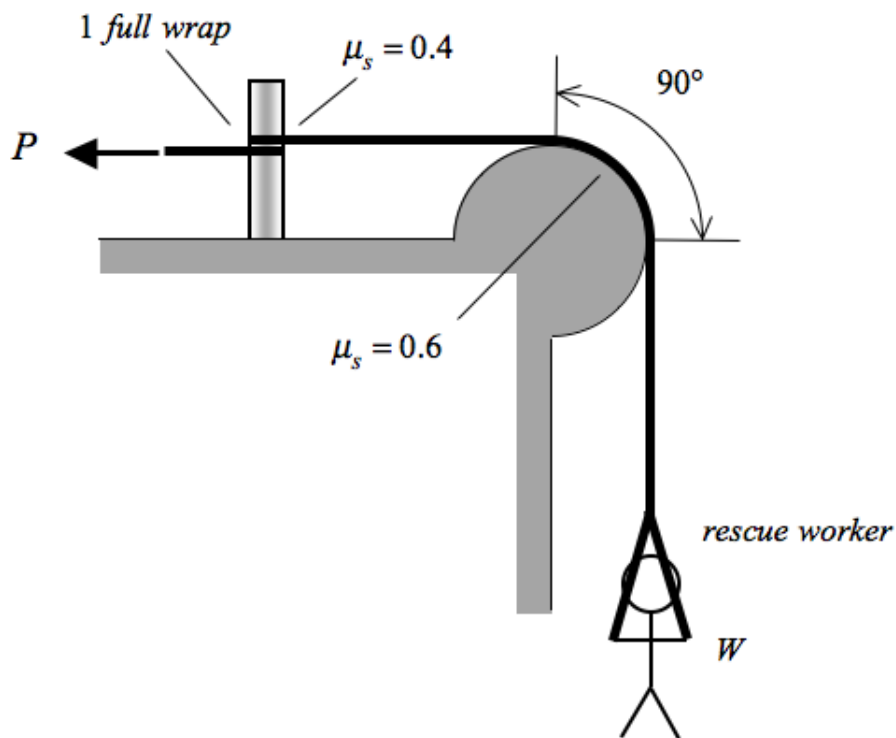

**Example 10.5.3**

A motor exerts a clockwise torque  $M_A$  on pulley A. A counterclockwise torque  $M_B$  is applied to pulley B that keeps the system in equilibrium. The coefficient of static friction between the belt and the pulleys is known to be  $\mu_s = 0.35$ . Determine the maximum torque  $M_A$  that can be applied by the motor such that the tension in the belt does not exceed a maximum allowable value of  $2500\text{N}$ . Determine the corresponding value for the torque  $M_B$ .

